

WEATHERPROOF TWIN EMERGENCY POD



Weatherproof Twin LED Emergency light



The Weatherproof Twin Emergency Pod is perfect for external applications where moisture or dust is present like car parks and storage areas.

Constructed with a polycarbonate enclosure with an IP66/67 rating and D160 classification.

With market leading lithium battery technology and energy efficient LEDs the Weatherproof Twin Emergency Pod will also deliver lower maintenance and energy costs.

Applications



Warehouses



Schools



Factories



Public Amenities



Car Parks



Stairwells

Features and Benefits

- AS/NZS 2293.3 compliant
- Twin rotatable LED pods
- IP66/67
- Nanophosphate® battery
- Clevertest Plus System compatible



WEATHERPROOF TWIN EMERGENCY POD

ORDERING INFORMATION		L10
TEST OPTIONS / PART #	Standard - White	LWP2LIFE-PRO-WPPOD
	Clevertest Plus System Compatible	Yes
	DALI	LWP2LIFE-PRO-WPPOD-DALI
	Zoneworks® XT Hive	LWP2LIFE-PRO-WPPOD-HV
Carton Quantity	1 Piece	
Weight - Single (Carton)	3.4kg	
Dimensions (L x W x H)	520mm x 180mm x 135mm	

POWER, LAMPS AND BATTERY	L10
Power Consumption (Standby / Max)	0.8W / 5.5W
Lamp(s)	Twin Dual LED
Battery	Lithium Nanophosphate®
Voltage (V) / Capacity (mAh)	3.3V / 2500mAh
Charging Method	Intelligent Current Limited Constant Voltage

TECHNICAL SPECIFICATIONS		CLASSIFICATION	L10 (CEILING MOUNT)
Operating Mode	Non-Maintained	C0	D160
Voltage (V) Frequency (Hz)	220-240V (50Hz)	C90	D160
Operating Temperature	0°C to 40°C		
IP Rating (IP)	IP66/67		

SPACING TABLE AND MOUNTING HEIGHTS – AS/NZS 2293.1:2018 (MINIMUM LIGHT LEVEL OF 0.2 LUX)														
Classification	2.1m	2.4m	2.7m	3.0m	3.3m	3.6m	4.0m	4.5m	5.0m	6.0m	7.0m	8.0m	9.0m	10.0m
D160	11.5	13.2	14.8	16.5	18.1	19.8	22.0	24.7	27.5	33.0	38.5	40.2	41.4	42.5

■ Care should be taken when spacing luminaires at the distances indicated by the shaded regions to ensure conformance to AS/NZS2293.1, Clause 4.3 is maintained. A single emergency luminaire shall not serve an area of greater than 500 m².

For 1 lux and AS/NZS 2293.1:2005 spacing tables please visit:
<https://clevertronics.com.au/spacing-tables/>

*Warranty information located at:
<https://clevertronics.com.au/warranty-statement/>

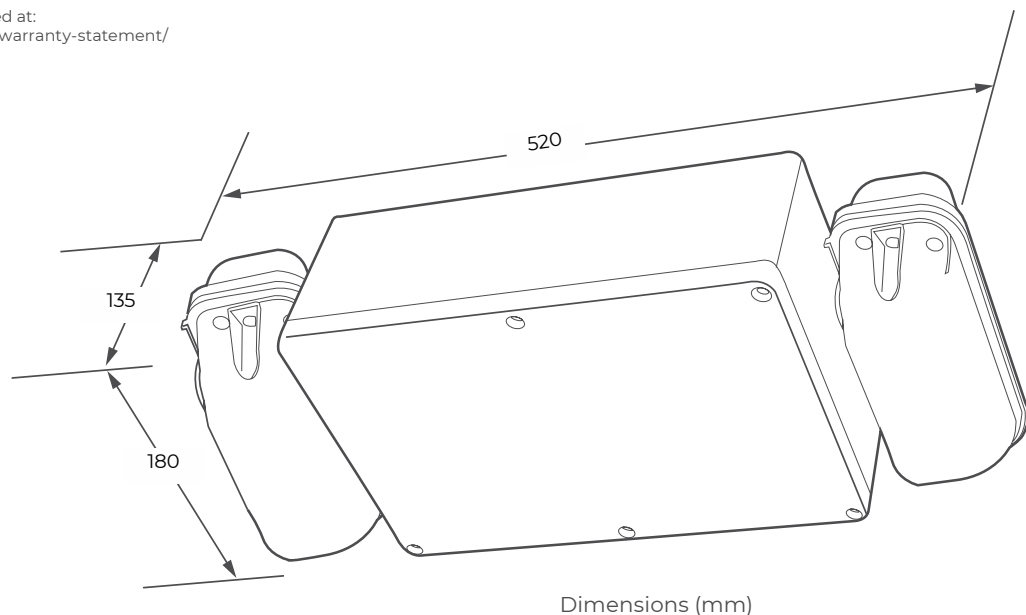

clevertronics.co.nz
clevertronics.com.au

1 Caribbean Drive, Scoresby VIC 3179
 P +61 3 9559 2700 F +61 3 9559 2799 E info@clevertronics.com.au

Clevertronics is committed to continuously improving its products.
 All features and specifications are subject to change without prior notice.
 _PRODUCT SHEETS – ANZ Weatherproof Twin Pod Emergency 04OCT22

